

Specifications

Models	Z-33/18	
Measurements	Metric	US
Working height maximum*	12 m	39 ft 4 in
Platform height maximum	10 m	32 ft 10 in
Horizontal reach maximum	5.57 m	18 ft 3 in
Up and over clearance maximum	4.28 m	14 ft 1 in
A Platform length	0.76 m	2 ft 6 in
B Platform width	1.17 m	3 ft 10 in
C Height - stowed	1.98 m	6 ft 6 in
D Length - stowed	4.17 m	13 ft 8 in
E Width	1.50 m	4 ft 11 in
F Wheelbase	1.90 m	6 ft 3 in
G Ground clearance - center	15.2 cm	6.0 in

Productivity

Lift capacity	200 kg	440 lbs
Turntable rotation	400° non-continuous	
Turntable tailswing at counterweight	zero	zero
Turntable tailswing - riser up	0.15 m	5.2 in
Turntable tailswing - riser down	1.16 m	3 ft 10 in
Drive speed - stowed	6 km/h	3.7 mph
Drive speed - raised retracted**	0.75 km/h	0.47 mph
Drive speed - raised extended**	0.23 km/h	0.14 mph
Gradeability - stowed***	30%	30%
Turning radius - inside	1.9 m	6 ft 3 in
Controls	24 V DC proportional	
Tyres	56x23x44 cm	22x9x17 in

Power

Power source	48 V DC (eight 6 V X 8 batteries 315 Ah capacity)	
Drive system	48 V 3 phase AC	
Auxiliary power unit	24 V DC	24 V DC
Hydraulic tank capacity	20.8 L	6 gal

Sound & Vibration Levels

Sound pressure level (ground)	<70 dBA	<70 dBA
Sound pressure level (platform)	<70 dBA	<70 dBA
Vibration	<2.5 m/s ²	<8 ft 2 in/s ²

Weight****

	3,665 kg	8,080 lbs
--	----------	-----------

Standards Compliance

EU Directives: 2006/42/EC - Machinery (harmonized standard EN280); 2004/108/EC (EMC); 2006/95/EC (LVD)

Range Of Motion Z-33/18

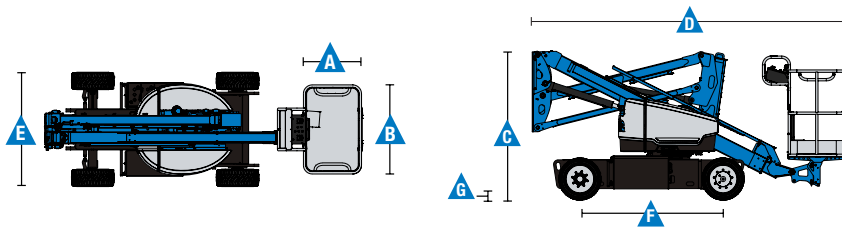
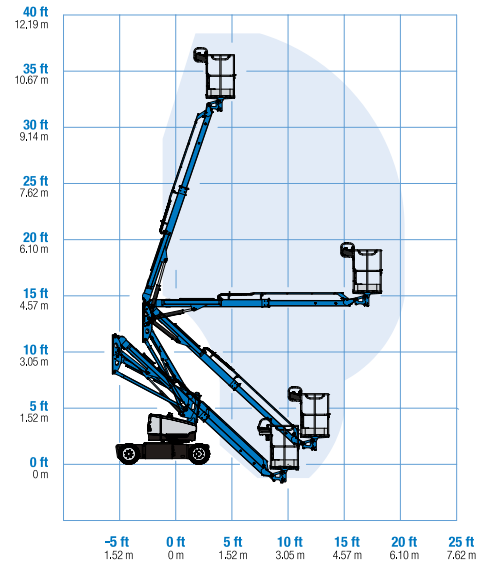

* The metric equivalent of working height adds 2 m to platform height. U.S. adds 6 ft to platform height.
 ** In lift mode (platform raised), the machine is designed to operate on firm, level surfaces only.
 *** Gradeability applies to driving on slopes. See operator's manual for details regarding slope ratings.
 **** Weight will vary depending on options and/or country standards.

Self-Propelled Articulating Booms

Z[®] -33/18

Features

Standard Features	Easily Configured To Meet Your Needs	Options & Accessories
<p>Measurements</p> <p>Z-33/18</p> <ul style="list-style-type: none"> • 12 m (39 ft 4 in) working height • 5.57 m (18 ft 3 in) horizontal reach • 4.28 m (14 ft 1 in) up and over clearance • Up to 200 kg (440 lbs) lift capacity <p>Productivity</p> <ul style="list-style-type: none"> • 1.50 m (4 ft 11 in) width • 1.9 m (6 ft 3 in) inside turning radius • Self-leveling platform • Fast Mast™ System • Proportional joystick controls • Telematics-Ready Connector • Thumb rocker steer • Drive enable • Chassis tilt drive function cut-out • AC power cord to platform • Horn • Hour meter • Tilt alarm • Descent & travel alarms • Flashing beacon • 400° non-continuous turntable rotation • Variable speed high efficiency hydraulic power unit • AC electric drive system • Traction control • On board easy to understand diagnostics • Electric brake release • Drive at full height • Entry Toe Boards and step • Lift Guard™ Contact Alarm <p>Power</p> <ul style="list-style-type: none"> • 48 V DC deep cycle battery pack • 24 V DC auxiliary power • Universal 30A battery smart charger • Battery charge indicator • Low battery voltage interrupt • 48 V solid state battery charger 	<p>Platform</p> <ul style="list-style-type: none"> • Steel 1.17 m (3 ft 10 in) <p>Power</p> <ul style="list-style-type: none"> • 48 V DC (eight 6 V 350 Ah batteries) <p>Drive</p> <ul style="list-style-type: none"> • 2 x 4 Electric AC <p>Tyres</p> <ul style="list-style-type: none"> • Solid rubber non-marking • Multi-purpose tyres ⁽¹⁾ (not interchangeable with standard tyres) 	<p>Productivity</p> <ul style="list-style-type: none"> • Air line to platform ⁽¹⁾ • Power to platform: plug, socket, with optional Residual-current Circuit Breaker with Overcurrent protection • Work lights package (2 on chassis, 2 on platform) ⁽²⁾ • Track & Trace ⁽²⁾ (GPS unit providing machine location & operating information) • Lockable platform control box cover • Chassis tilt lift function cut-out (software setting)



⁽¹⁾ Factory-fit option only
⁽²⁾ Includes a first 2 years subscription

United Kingdom

The Maltings, Wharf Road, Grantham NG31 6BH, T: +44 800 988 3739 (toll free), Fax +44 (0)1476 584334, Email AWP-InfoEurope@terex.com
Visit www.genielift.co.uk/locations to view our global locations list.

Worldwide Manufacturing And Distribution

Australia · Brazil · Caribbean · Central America · China · France · Germany · Italy · Japan · Korea · Mexico · Russia · Southeast Asia · Spain · Sweden · United Arab Emirates · United Kingdom · United States

Product specifications and prices are subject to change without notice or obligation. The photographs and/or drawings in this document are for illustrative purposes only. Refer to the appropriate Operator's Manual for instructions on the proper use of this equipment. Failure to follow the appropriate Operator's Manual when using our equipment or to otherwise act irresponsibly may result in serious injury or death. The only warranty applicable to our equipment is the standard written warranty applicable to the particular product and sale and we make no other warranty, express or implied. Products and services listed may be trademarks, service marks or trade names of Terex Corporation and/or their subsidiaries in the USA and many other countries. Genie is a registered trademark of Terex South Dakota, Inc. © 2018 Terex Corporation.

